

# s11.3 litterbin



## description

316 grade stainless steel with satin finish outer construction on level adjustment galvanized base. Omos patented ashtray. Front opening with concealed stainless steel hinge and slam latch. 90L liner.

## dimensions

Height 1070mm, width 530mm, depth 400mm.  
Capacity 90L.  
Weight 62Kg.

## options

Galvanized or plastic liner.  
Choice of decal.

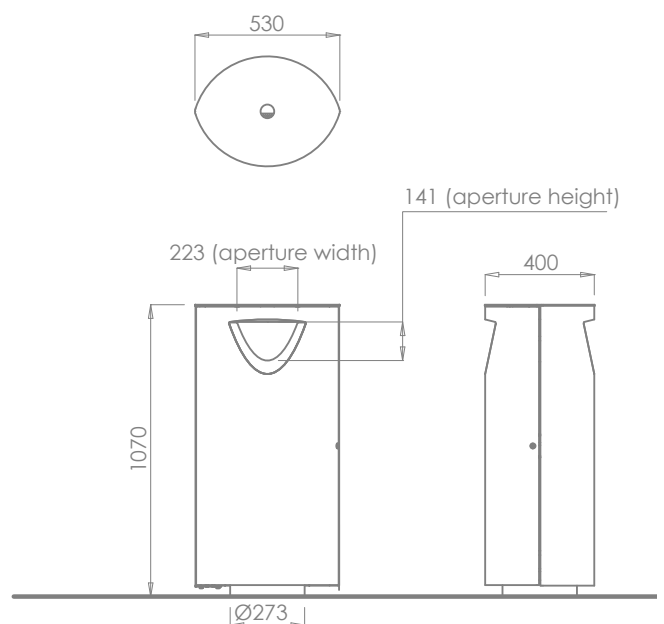

# s11.3 Fixing Instructions

(for areas already paved)

- 1 Determine the location for the bin. Remove pavers and excavate a hole to minimum dimensions of L600 x W600 x D400mm. The size of the foundation may vary depending on the ground conditions. Foundations must be to Engineer's specification.
- 2 Fill the hole with 35N20 concrete up to 15mm below the level of the underside of the pavers ensuring a good smooth surface finish.
- 3 Allow sufficient time for the concrete to set then apply a layer of dry sand/cement mix over the pad. Compact and adjust to bring this to the level of the underside of the paving.
- 4 Replace the paving slabs and ensure that they are well bedded in.
- 5 Place the levelling base (galvanized steel ring found in bin liner) in the desired location and mark through the fixing holes making sure this is done accurately. **IMPORTANT:** the orientation of the bin is determined by the direction of the base, the projecting threaded bars are in line with the long axis of the bin.
- 6 Drill through pavers into the concrete pad. Drill following fixing manufacturer's instructions to suit the chosen fixing. Use M12 through bolts to fix (such as Hilti HSA M12 x 180).
- 7 Tighten the levelling base.
- 8 Lift the bin into place and start the M16 nuts on the threaded bar (leave loose).
- 9 Set the level of the bin using the four adjuster bolts.
- 10 Tighten the two M16 nuts.

## Foundations

The bin can be fixed directly to a concrete slab or to concrete pads beneath paving stones. Foundations must be to engineer's specification.

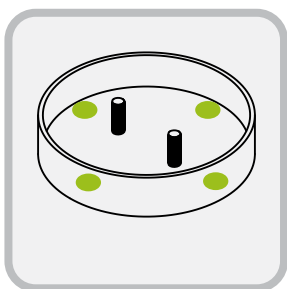

**Right and above,** fixing details.

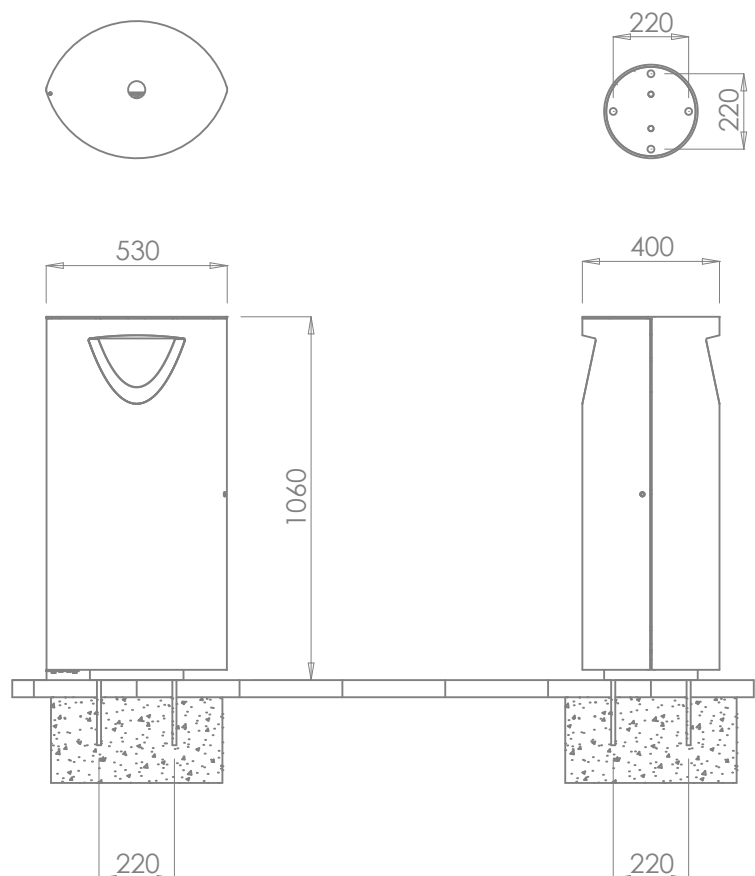

# s11.3 Care and Maintenance Guidelines

The s11.3 litterbin is constructed from 316 grade stainless steel with a heavy duty galvanized steel base, materials which are highly corrosion resistant. The external finish of the bin is a satin or brushed polish. Despite the material's corrosion resistant properties some care is required to maintain a bright appearance. The extent to which cleaning is required will depend on a number of factors including environmental conditions, construction activity and level of use.

## Maintaining the stainless steel

Prior to shipping all our stainless steel has been passivated to ASTM A380 and ASTM 976 01-8.1 to ensure the highest standard.

Clean the stainless steel components using warm water with a mild detergent with a non abrasive cloth or sponge. Heavier stains may require the use of a nylon scouring pad. As a rule always start with the least severe method of cleaning as the use of scouring pads or scotch bright may result in altering the surface texture. In the case of a bead blasted finish, where abrasive cleaning is required, always use a random circular rubbing action. In the case of brushed finishes the surface consists of uniform fine 'scratches' running in one direction so where abrasive cleaning is required always use a straight back and forward rubbing action in the direction of the grain. If you are in doubt as to which type of finish you are dealing with contact Omos on + 353 [0]45 899802.

Rust spots or 'tea stains' can occur on the surface of the material, these are normally caused by contamination from ordinary mild steel, particular in areas where construction work has been undertaken. Such stains can be removed using an abrasive pad as described above.

In cases where the surface is severely stained as a result of severe environmental conditions or scratched due to misuse, it may still be possible to restore the original finish. Contact Omos for advise on such issues.

There are many stainless steel polishes available to enhance the surface finish. Omos recommends 'Avesta Finishing chemicals' and can advise where to purchase.

## Maintaining the galvanized steel

Clean regularly with warm soapy water and a scouring pad. Should the galvanized coating be penetrated apply 'cold galvanizing' paint to damaged area. For more information on remedial work contact Omos.

## Liner

The s11.3 litterbin is equipped with a plastic liner. To prolong the life of the liner Omos recommends using plastic bin liners. This will also prevent seepage of liquids onto the surrounding pavement.

## Locks, hinges and other moving parts

All moving parts should be kept clean and lubricated to ensure a long life. A spray lubricant such as 'WD40' is widely available and well suited.



**Right**, chamfer aperture version.