

s36 cycle stand



Above and right, s36 cycle stands in stainless steel, root fixed.

description

316 grade stainless steel with a brushed polish finish.

dimensions

Height 825mm, width 850mm, outside diameter 50.8mm, wall thickness 1.5mm.

options

Available as root fixed, below surface flange or above surface flange fixed. Galvanized mild steel option.

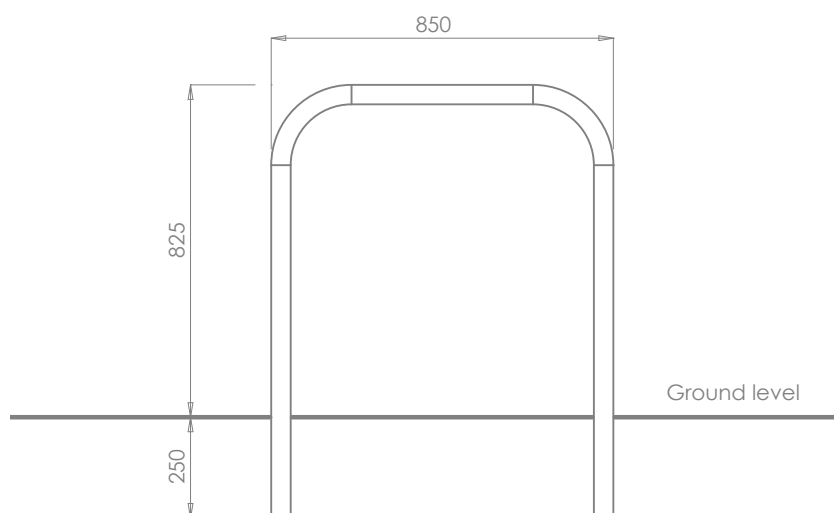

s36 AGFF Fixing Instructions

(for areas already paved)

- 1 Ensure that the surface which the cycle stand is to be fixed to is of sufficient size and strength for this purpose.
- 2 Position the cycle stand in the desired location and mark hole positions.
- 3 Drill following fixing manufacturer's instructions to suit the chosen fixing. Choose a fixing which will accept an M10 SS CSK bolt, either a mechanical anchor (such as Hilti HSC-IR M10*60) or an internally threaded fixing designed for chemical fixing (such as Hilti HIS-RN M10xL [length to suit]). **IMPORTANT**, the depth of the hole must be sufficient to allow the fixing to be fully embedded in the concrete rather than partially in the paver and partially in the concrete.
- 4 Insert the fixings into the ground following fixing manufacturer's instructions. Reposition the cycle stand and screw in M10 SS CSK (stainless steel with countersunk head) into the 4 no. fixings. Where chemical fixing is used (such as Hilti HIT-HY 150) leave sufficient time to cure before. Tighten the bolts.

Foundations

Foundations must be to engineers specification.

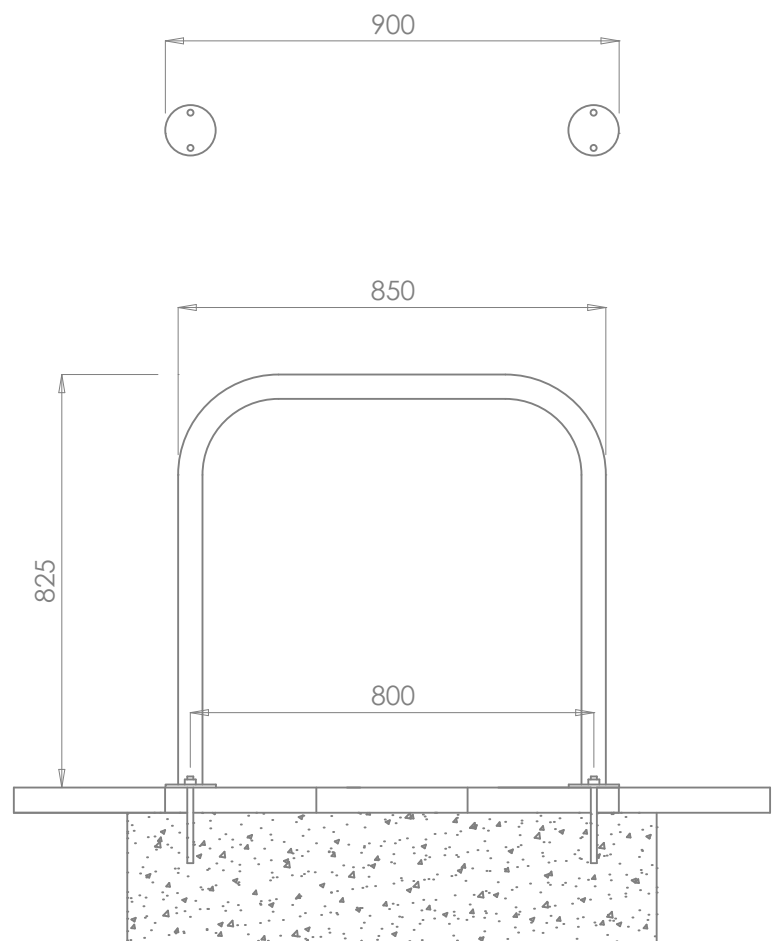

Above, fixing details.

s36 BGFF Fixing Instructions

(for areas already paved)

- 1 Cast foundation to engineers specification where cycle stand is to be located. The surface of the foundation must be level and finished to 210mm +10mm, -10mm. Leave to fully cure.
- 2 Position the cycle stand in the desired location and mark hole positions.
- 3 Drill 12mm holes to a depth of 150mm, use M12 through bolts to fix (such as Hilti HSA M12 x 120).
- 4 Use shims if necessary to ensure the correct height and plumb. Tighten cycle stand in position.
- 5 Where necessary cut or core drill the paving slabs and reinstate.
- 6 Render neatly around bollard with non shrink grout, removing any grout residue.

Foundations

Foundations must be to engineer's specification.

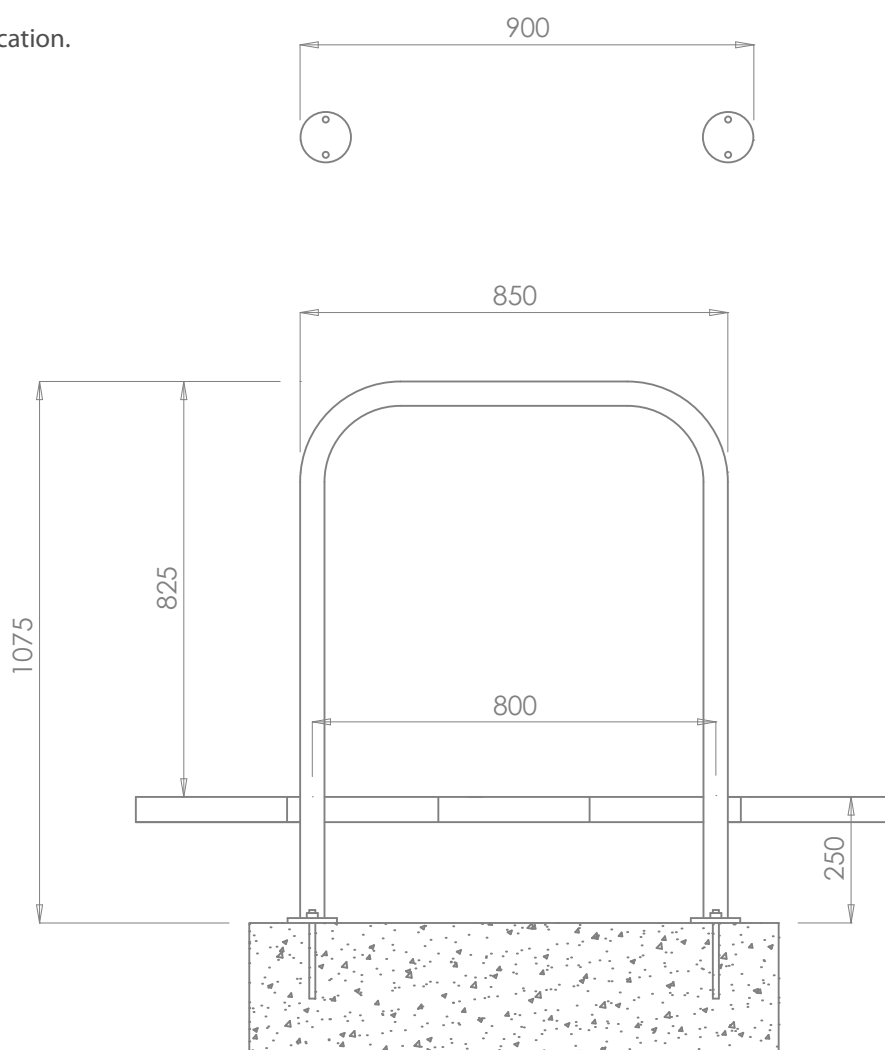

Above, fixing details.

s36 RF Fixing Instructions

(for areas already paved)

- 1 Set out the position of the cycle stand/s.
- 2 Where the area has been paved remove sufficient pavers to facilitate excavation.
- 3 Excavate holes to engineer's specification.
- 4 Position cycle stand precisely ensuring correct position, height and plumb. Prop securely in position.
- 5 Back fill holes with concrete (35N20) leaving sufficient depth for paving slabs and bedding.
- 6 Once set remove props.
- 7 Where necessary cut or core drill the paving slabs and reinstate.
- 8 Render neatly around cycle stand with non shrink grout, removing any grout residue.

Foundations

Foundations must be to engineer's specification.

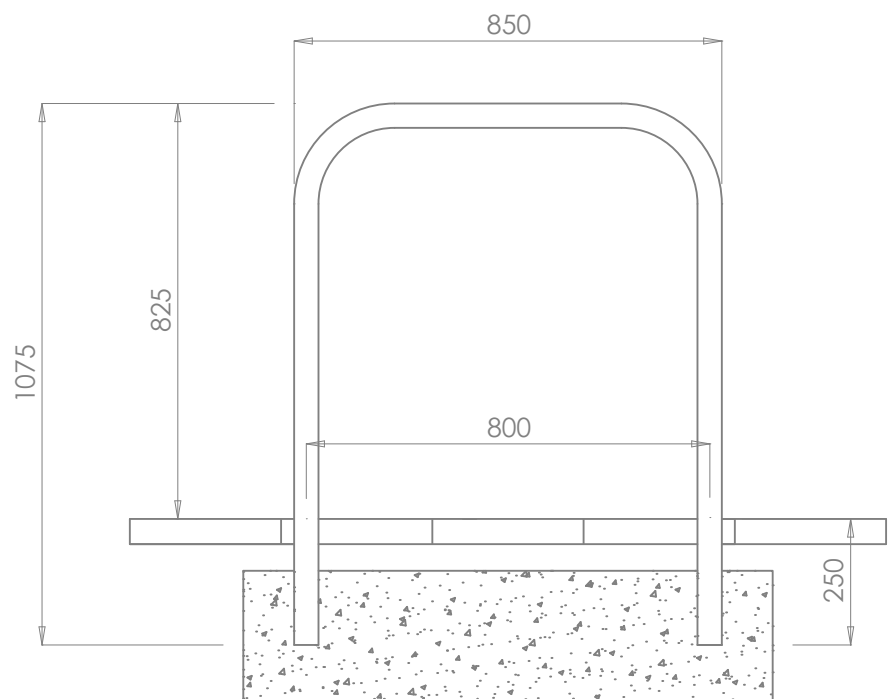

Above, fixing details.

s36 Care and Maintenance Guidelines

The s36 cycle stand is constructed from 316 grade stainless steel, a material which is highly corrosion resistant. The finish is a satin or brushed polish.

Despite the material's corrosion resistant properties some care is required to maintain a bright appearance. The extent to which cleaning is required will depend on a number of factors including environmental conditions, construction activity and level of use.

Maintaining stainless steel

Prior to shipping all our stainless steel has been passivated to ASTM A380 and ASTM 976 01-8.1 to ensure the highest standard.

Clean the stainless steel components using warm water with a mild detergent with a non abrasive cloth or sponge. Heavier stains may require the use of a nylon scouring pad. As a rule always start with the least severe method of cleaning as the use of scouring pads or scotch bright may result in altering the surface texture. In the case of brushed finishes the surface consists of uniform fine 'scratches' running in one direction so where abrasive cleaning is required always use a straight back and forward rubbing action in the direction of the grain. If you are in doubt as to which type of finish you are dealing with contact Omos on + 353 [0]45 899802.

Rust spots or 'tea stains' can occur on the surface of the material, these are normally caused by contamination from ordinary mild steel, particularly in areas where construction work has been undertaken. Such stains can be removed using an abrasive pad as described above.

In cases where the surface is severely stained as a result of severe environmental conditions or scratched due to misuse, it may still be possible to restore the original finish. Contact Omos for advice on such issues. There are many stainless steel polishes available to enhance the surface finish. Omos recommends 'Avesta Finishing chemicals' and can advise where to purchase.

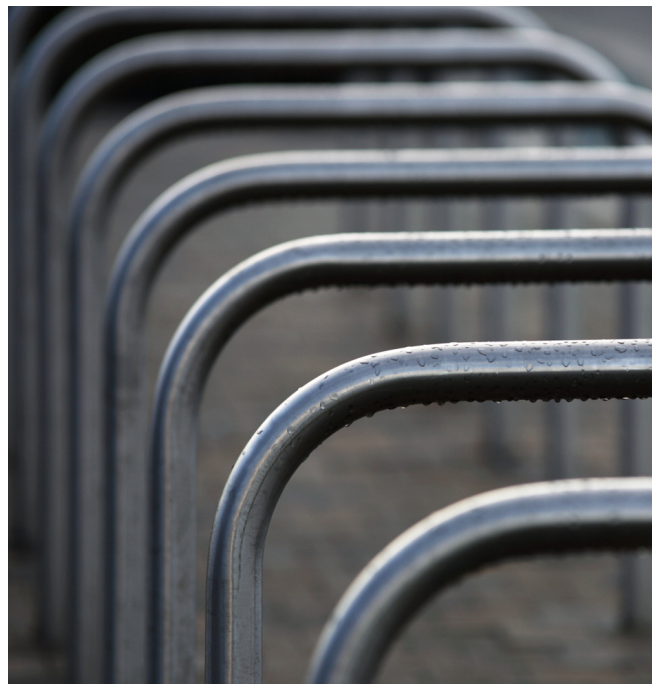

Right, s36 cycle stand detail.