

# s65 tree grille



## description

Galvanized steel concentric rings split in four quadrants and set on steel sub-frame.

## dimensions

Outside diameter 1000mm, inner diameter 520mm.

## options

Range of colours available.

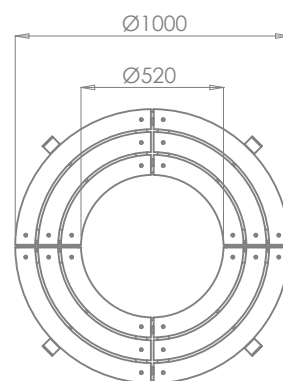

# s65 Fixing Instructions

- 1 Level the soil around the tree to approximately 50mm below finished paving level.
- 2 Remove soil at 4 no. positions around the perimeter where the frame tabs are to be located (note the orientation of the joints will be determined by the orientation of the frame).
- 3 Place the two halves of the frame around the tree and insert 4 no. bolts and tighten.
- 4 Level the frame, the top surface should be 10mm below finished paving level.
- 5 If required cast the 4 no. frame tabs in concrete haunchings.
- 6 Place the 4 no. segments on the frame and ensure they are level and aligned.
- 7 Pave up to edge of tree grille.

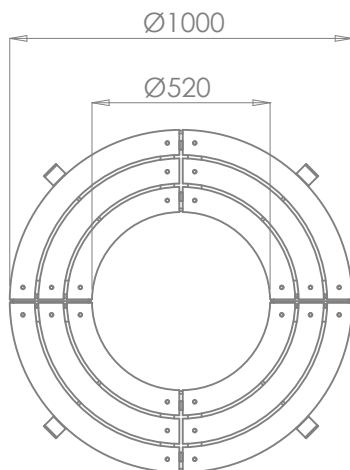
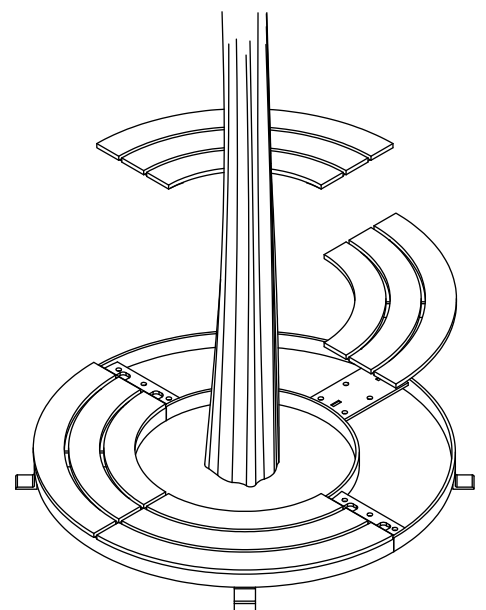
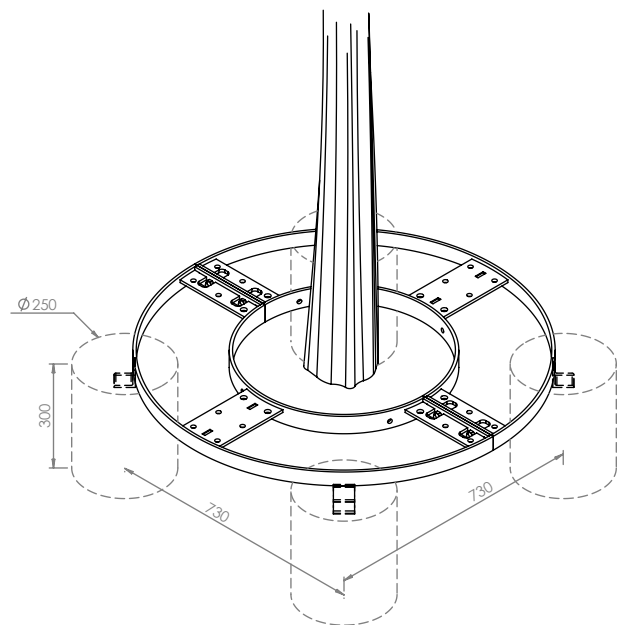
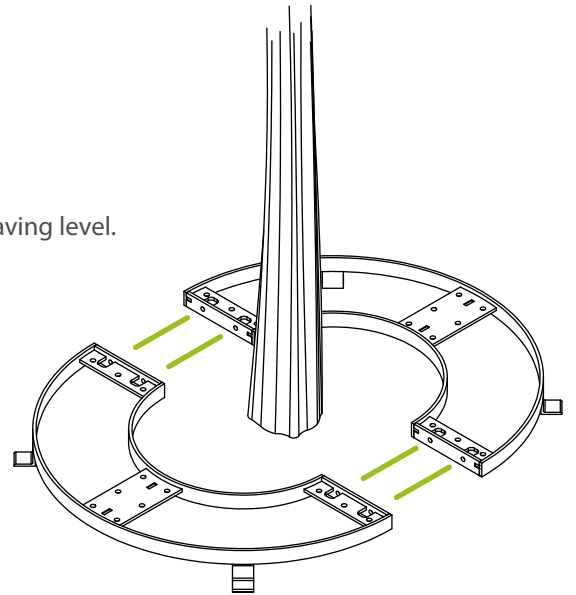

*Above, fixing details.*

# s65 Care and Maintenance Guidelines

The s65 tree grille is constructed from galvanized mild steel with a polyester powder coated finish. Some care is required to maintain the product's original appearance. The extent to which maintenance is required will depend on a number of factors including environmental conditions, construction activity and level of use.

## **Maintaining the painted galvanized steel**

The s65 is finished in polyester powder, a plastic coating which is baked onto the components prior to assembly. This is a highly durable finish which will last for many years.

To maintain the original appearance of the metalwork it should be cleaned regularly using warm soapy water. Avoid the use of abrasive cleaners as they may damage the surface finish. Should the paint become chipped or scratched it can be touched up using acrylic based paint.

If the damage has penetrated the galvanized coating the area should be cleaned with a wire brush and a zinc rich primer should be applied prior to the top coat. For further advice contact Omos on + 353 45 899802.