



OMOS

s21.2 Modular Planter

www.omos.ie
+ 353 45 899 802



s21.2 Modular Planter

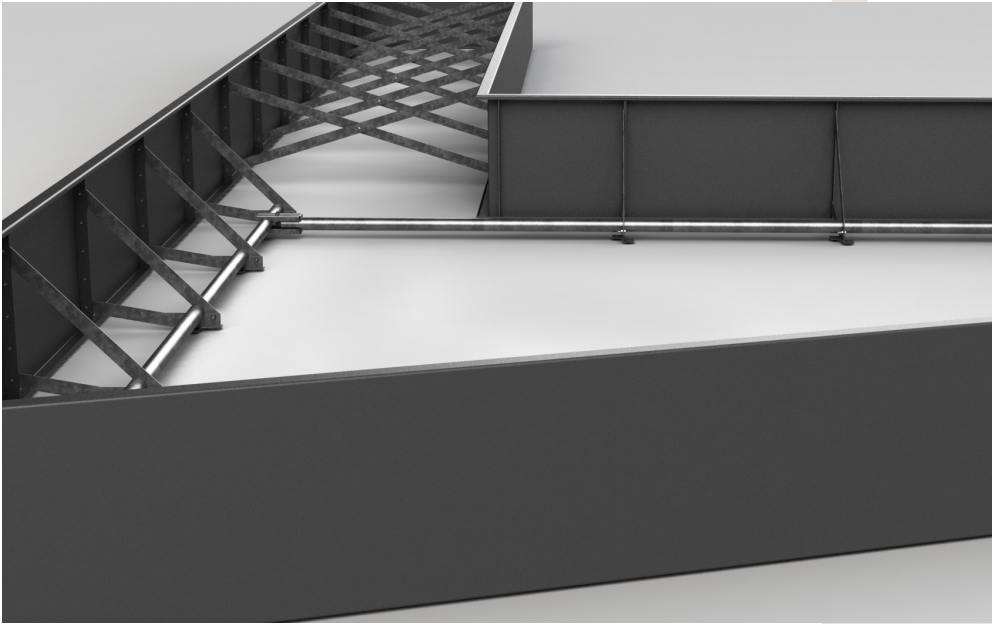

DESCRIPTION

Modular planter in aluminium with a powder coated finish or Corten steel. Infinitely variable in size and shape, panels are produced in straight pieces up to 3m long and combined with formed corners of any angle to follow your individual outline. Internal reinforcing, either cross strapping, bolt down gussets or our unique design registered self-supporting perimeter pole system is used to brace the panels internally.

DIMENSIONS

Heights from 400mm up to 900mm.

OPTIONS

Choice of RAL colours for powder coating.
Choice of metal.
With or without lighting.

Constructed from aluminium with a powder coated finish or Corten, the s21.2 modular planter offers a sleek and durable solution for showcasing greenery in any outdoor space.

From simple rectilinear shapes of any sizes to complex outlines, this modular design makes all sizes and shapes of planter possible. Internal reinforcing is provided by a unique independent system (free from ground fixing) or bolt down gussets or cross straps.

The planter is internally reinforced by Omos' unique independent reinforcing system (free from ground anchors) or conventional bolt down gussets or cross straps.



s21.2 Fixing Instructions

REINFORCING STRAPS 1/2

PANEL + STRAP ASSEMBLY

1. Align planter panels & insert bolted connection.
2. Loosely close the bolted connection.
3. Align strap reinforcing & insert bolted connection at panel joiners top / bottom & then centrally on the strap.
4. Attach strap reinforcing at mid panel with bolted connection. Loosely close all bolted connections until planter is completely assembled. When planter is fully assembled & positioned then bolted connections should be tightened.

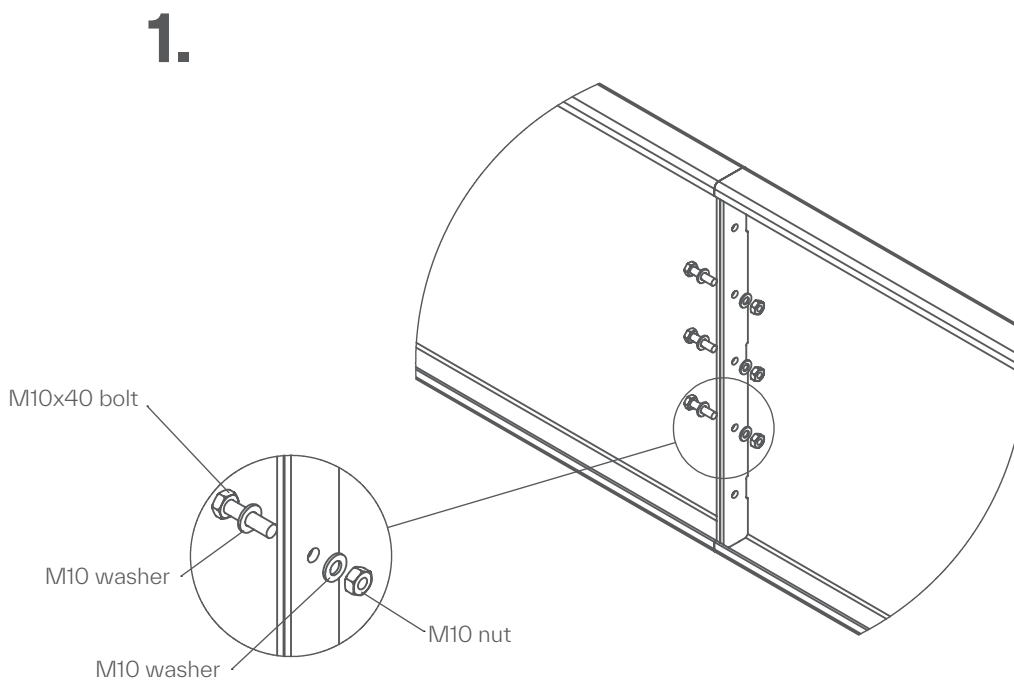

s21.2 Fixing Instructions

REINFORCING STRAPS 2/2

2.

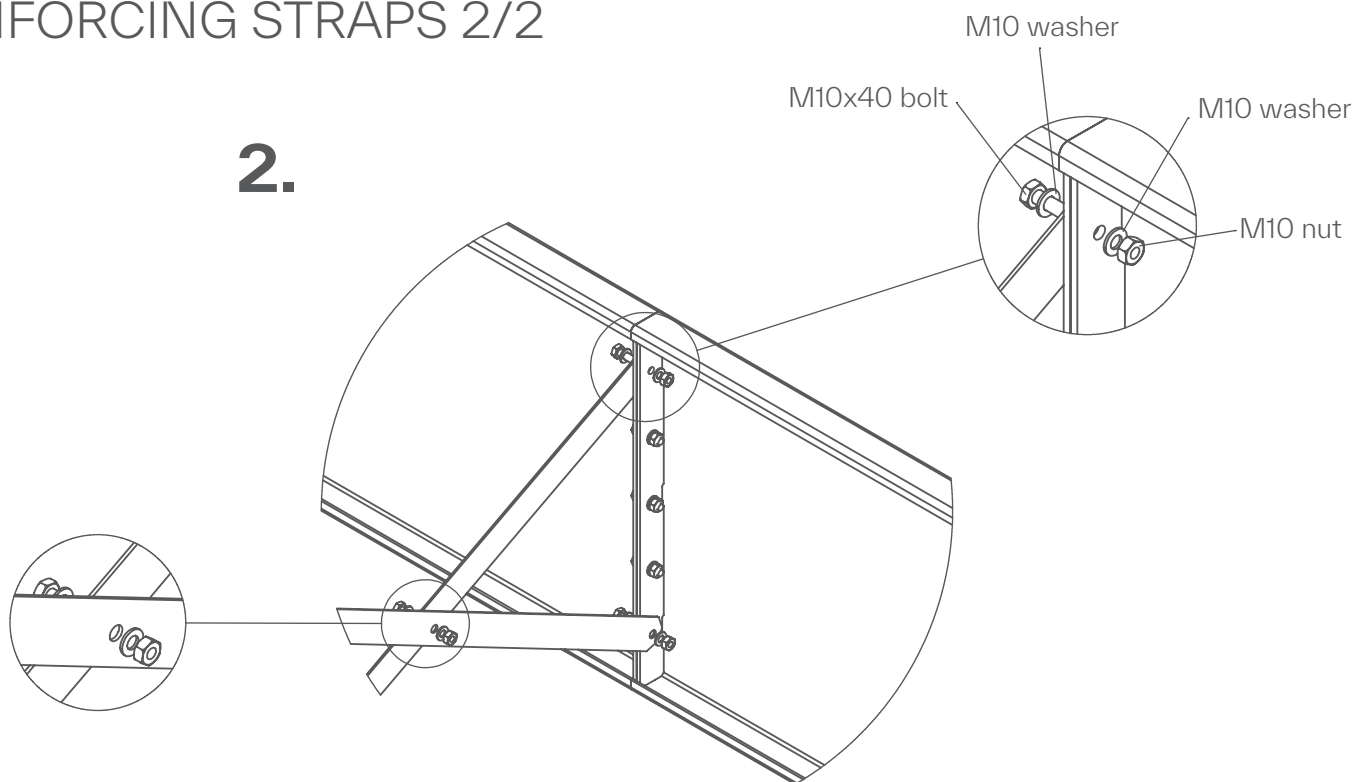

3.

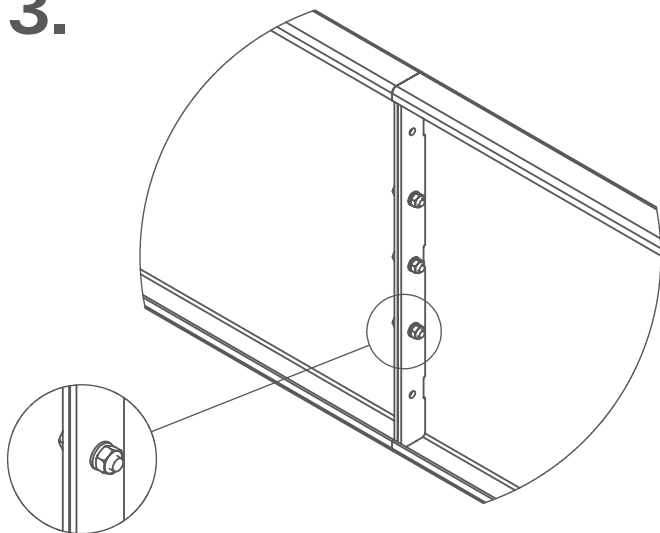

4.

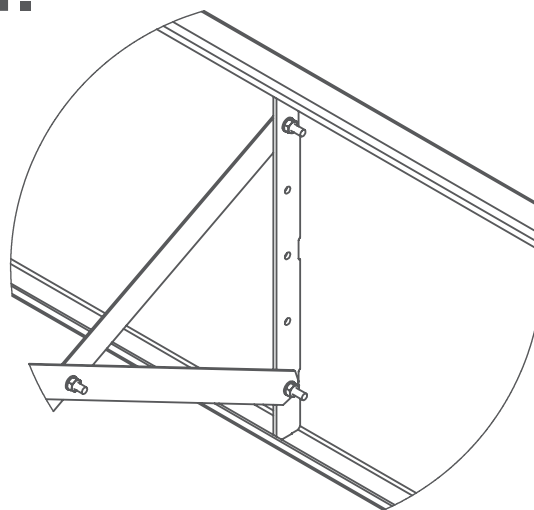

s21.2 Fixing Instructions

REINFORCING POLES 1/4

PANEL + POLE ASSEMBLY

1. Align planter panels and insert bolted connection.
2. Loosely close the bolted connection.
3. Align 'pole strap A' and insert bolted connection.
4. Align galvanized pole into position across 'pole strap A'. All bolted connections to be loosely fitted.
5. Attached pole strap B to the pole strap A and to the panel clamping the galvanized pole reinforcing in place.
6. Mid panel, pole reinforcing installation steps;
 1. Attach pole support A, at bolted connection A.
 2. Position galvanized pole reinforcing on top of pole strap A.
 3. Attach pole strap B at bolted connection B and C.
 4. Once planter is fully assembled and in position all bolted connections can be tightened.

1.

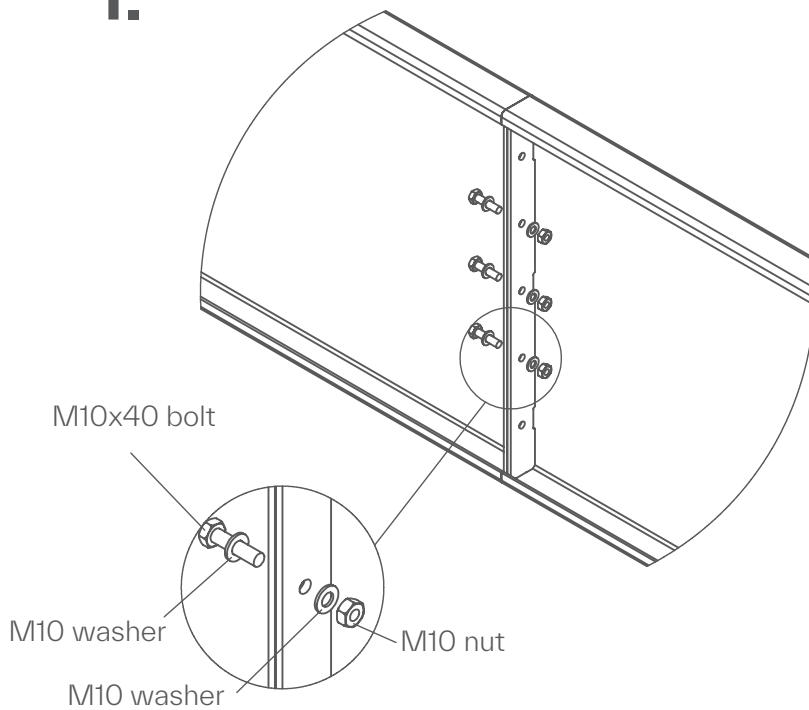

2.

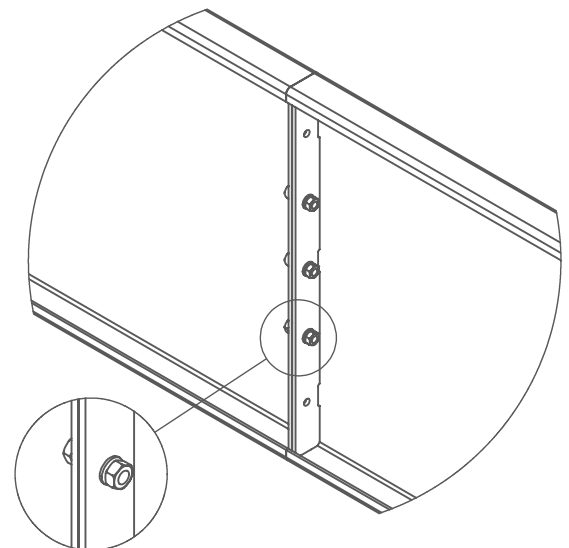

s21.2 Fixing Instructions

REINFORCING POLES 2/4

3.

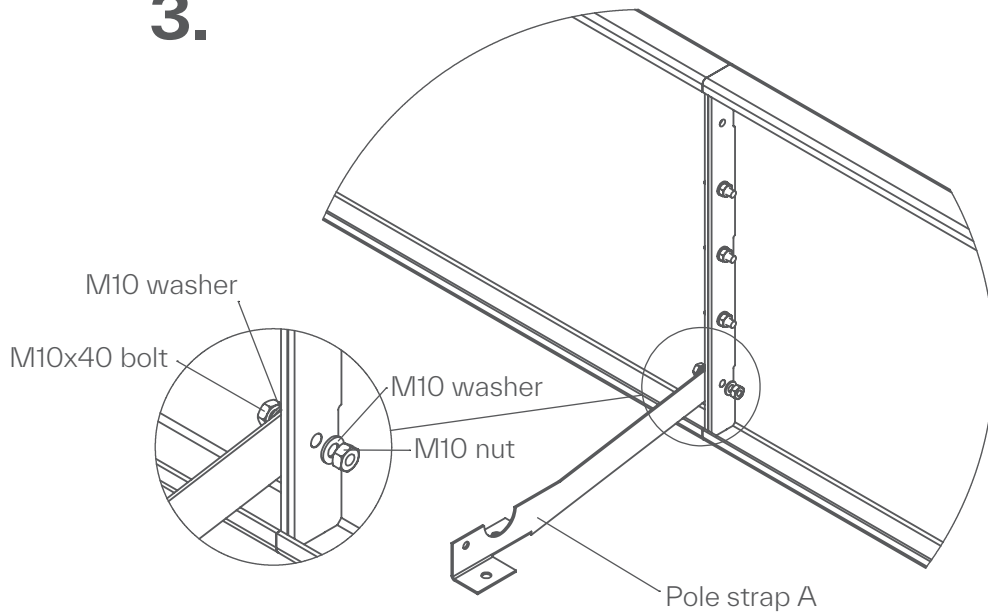

4.

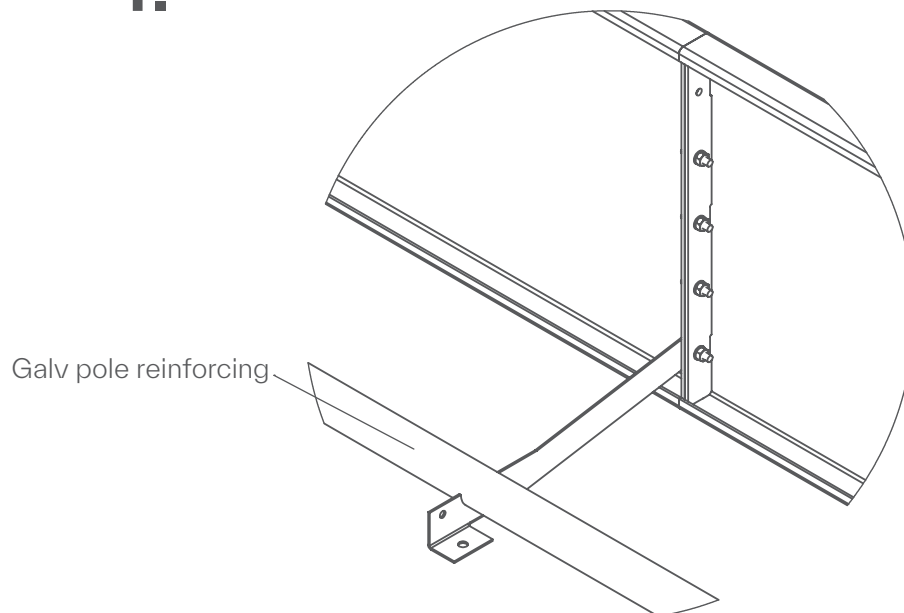

s21.2 Fixing Instructions

REINFORCING POLES 3/4

5.

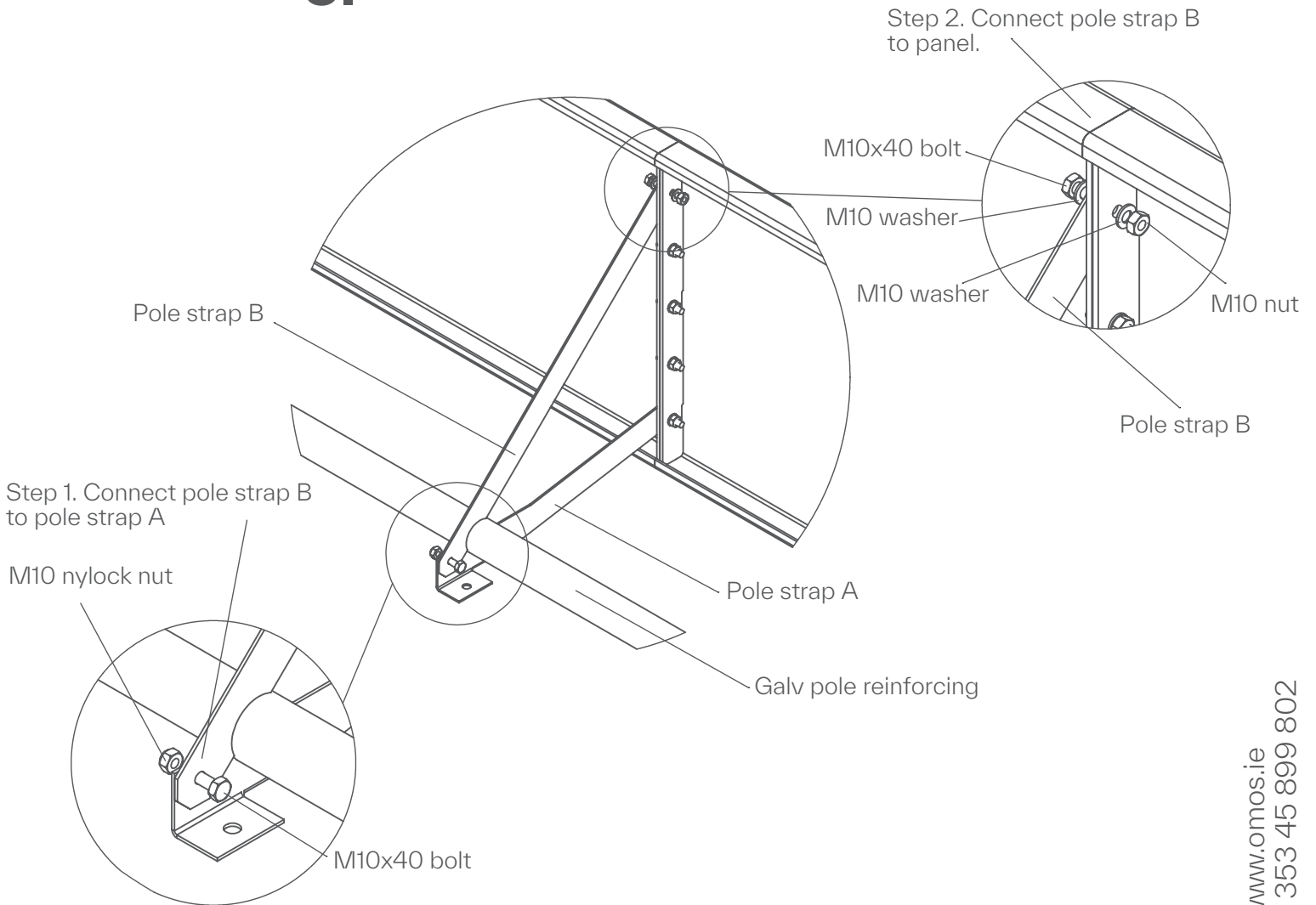

s21.2 Fixing Instructions

REINFORCING POLES 4/4

6.

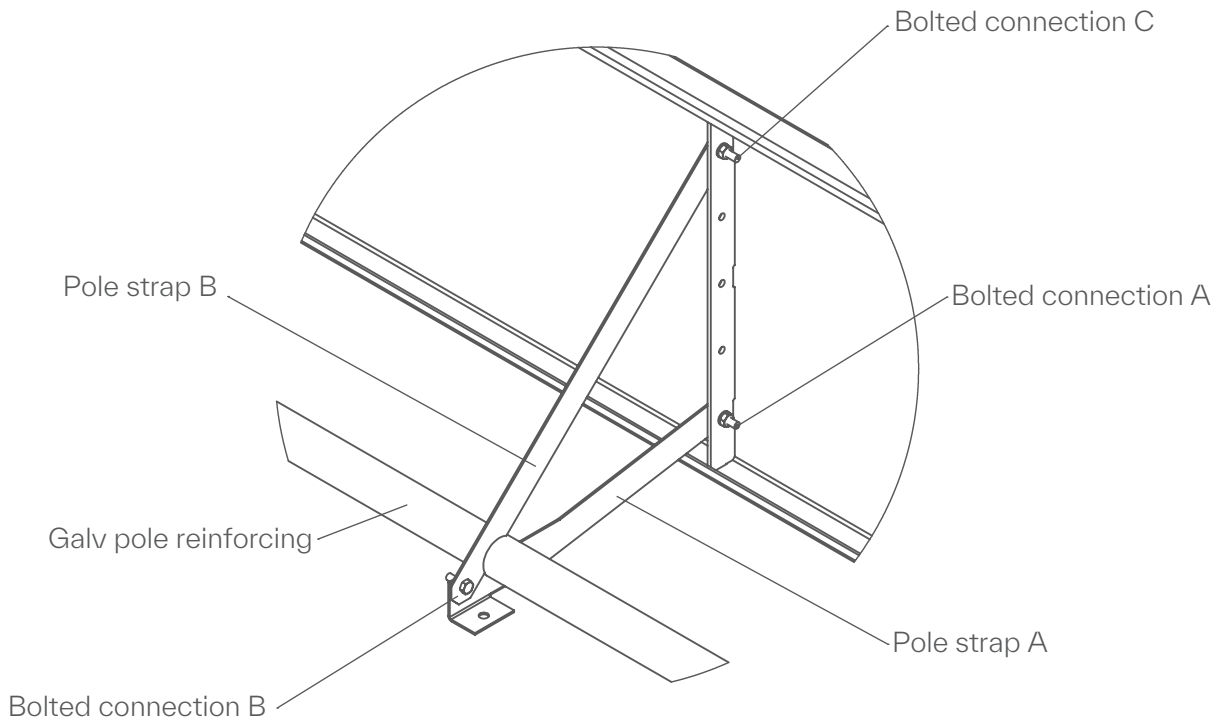

s21.2 Fixing Instructions

REINFORCING GUSSET 1/2

PANEL + POLE ASSEMBLY

1. Align planter panels with gusset and insert bolted connection.
2. Loosely close the bolted connection.
3. All bolted connections loosely fitted until planters are completely assembled.
4. Mid panels gussets follow the same steps;
 1. Align gusset with panels.
 2. Attached with bolted connection.
 3. All connections loose fitting until planter is fully assembled.
 4. Once planter is fully assembled and in position all bolted connections can be tightened.

1.

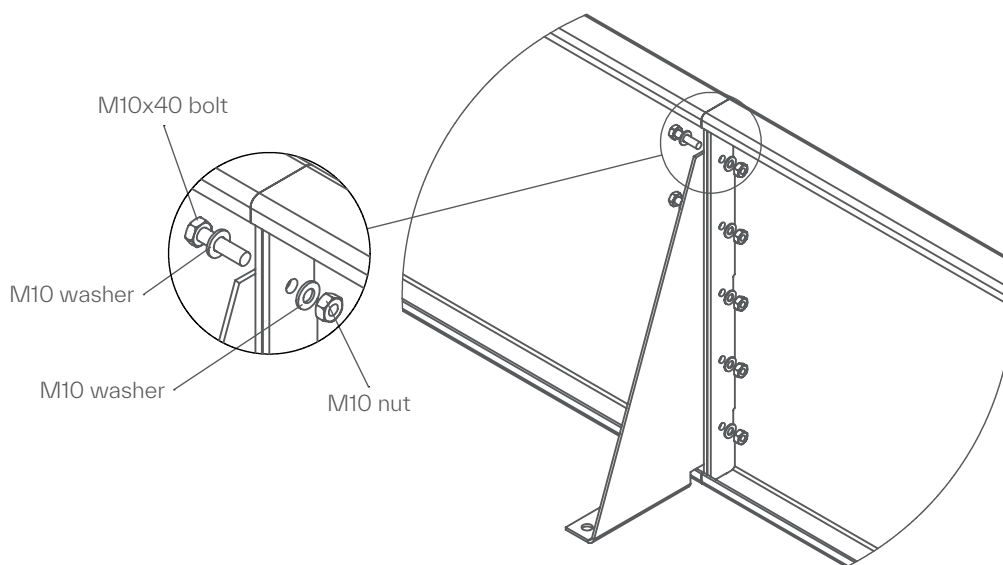

s21.2 Fixing Instructions

REINFORCING GUSSET 2/2

2.

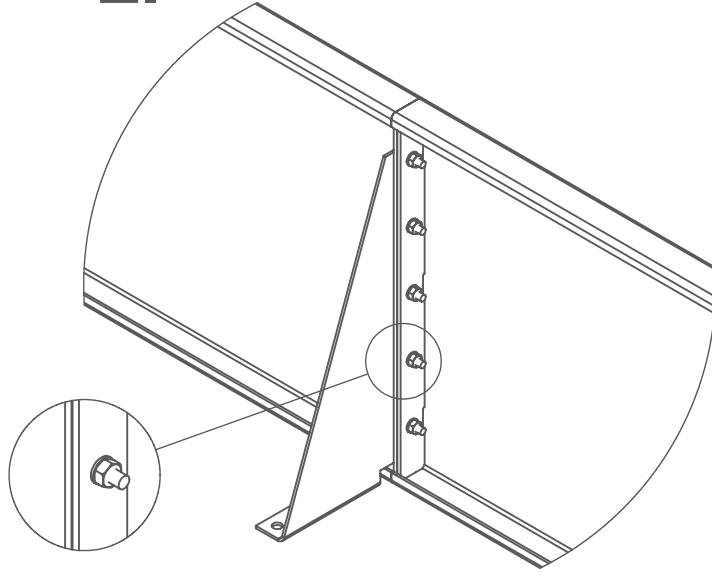

3.

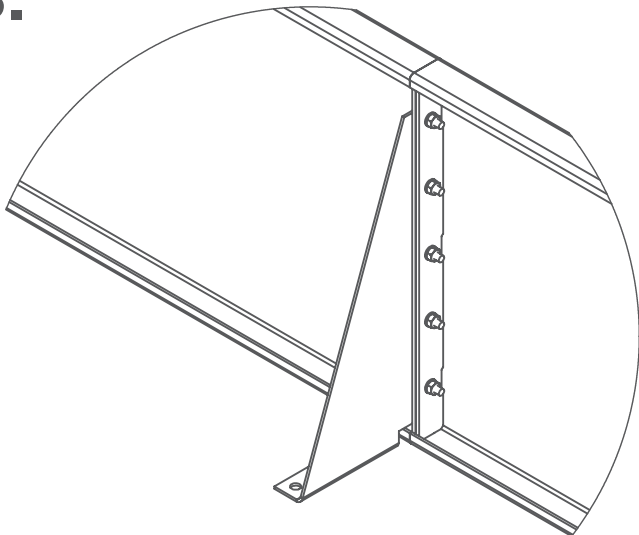

4.

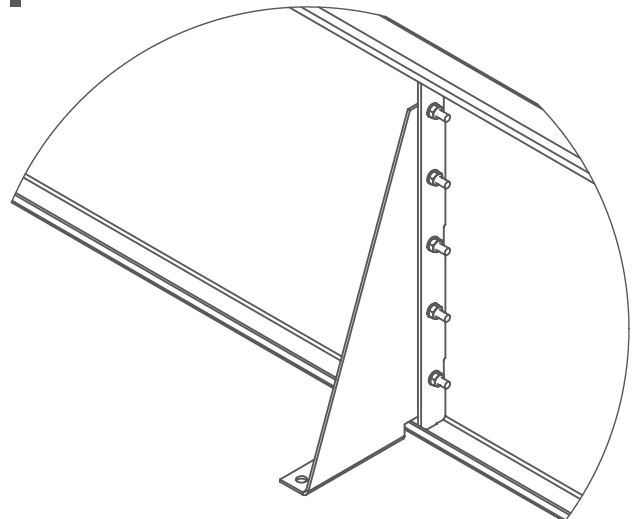

Maintaining Powder Coating



MAINTENANCE

Polyester powder coating is a dry finishing process where a polyester resin powder is applied to a metallic surface and then oven-baked. This creates a durable, protective finish that resists corrosion, weathering, and UV damage. Its versatility allows for a wide range of colour choices, ensuring vibrant and long-lasting aesthetics for diverse applications.

Despite its durability, some care is required to maintain the appearance of the material. The extent to which maintenance is required depends on a number of factors. These include environmental conditions, construction activity and level of use.

To maintain the original appearance of the metalwork, it should be cleaned regularly using warm soapy water. Avoid the use of abrasive cleaners as they may damage the surface finish.

Should the coating become chipped or scratched, it can be touched up using a colour matching metal paint. Where the surface becomes damaged clean with a wire brush or sandpaper, then paint with an outdoor metal paint. Omos recommends Uni 2k paint which can be purchased from most industrial or automotive paint suppliers. We recommend testing on a hidden area to ensure a good colour match before applying to the damaged region. For further advice contact Omos.

Weathering Steel



WEATHERING STEEL

Weathering Steel, also known as Corten (the original brand name), is an extremely durable material, which makes it suitable for many street furniture applications. Before choosing Weathering Steel, it's important to consider a potential downside: the pigmented runoff from the material. Until Weathering Steel fully stabilizes, this runoff may stain the ground beneath or transfer onto anything it comes into contact with, such as clothing.

Mitigation measures can be taken, such as gravel borders, or grating around objects. Sealers can be used where contact is likely, but they do detract from the natural look of the material and, unlike exposed Weathering Steel, do require maintenance.

Maintaining Weathering Steel



MAINTENANCE

Prior to shipping, all our weathering steel has been shot blasted to remove mill scale and give the surface an even finish. Once the material has been shot blasted, it has a grey metallic appearance but will quickly start to oxidize and turn orangey-brown, which darkens over time.

There may be some unevenness in the finish initially, as the initial formation of the passive layer sees a very distinctive change in colour over a short period of time. Any unevenness will disappear within a number of months. The patination process can be accelerated by the use of chemicals, but the simplest and safest way to speed up the process is by spraying the material with a saltwater solution over a period of a couple of weeks.

Should the Corten require cleaning this can be done using a scrubbing brush and warm water with a mild detergent. Avoid abrasive cleaners as they will remove or alter the texture of the weathered surface. Graffiti can be removed using a graffiti remover such as AF Graffiti Remover Gel GRG400.